

Not Transferable  
Security Classification: Non-Security



**बैंक नोट पेपर मिल इण्डिया प्रा. लिमिटेड**  
**BANK NOTE PAPER MILL INDIA PVT LIMITED**  
JV of SPMCIL - A Govt. of India Enterprises & BRBNMPL - A Subsidiary of RBI

**TENDER ENQUIRY FOR SUPPLY OF CLAMPING FINGERS AT BNPM PLANT, MYSURU**

This tender document contains 14 Pages

<b>Tender Enquiry No.</b>	<b>BNPM/OTE/359/2024-25</b>
<b>Tender issuing date</b>	<b>06.11.2024</b>
<b>Pre-bid meeting date &amp; time</b>	<b>Not Applicable</b>
<b>Due date &amp; time for bid submission</b>	<b>20.11.2024 @ 11.00 Hours</b>
<b>Mode of bid submission</b>	<b>Online</b>
<b>Type of tender</b>	<b>OPEN TENDER ENQUIRY (OTE)</b>
<b>Tender Processing Fee</b>	<b>Rs.100/- + Taxes</b>
<b>Details of contact person</b>	<b>Deputy General Manager (SCM) 0821-240111/175/180</b>

**Registered & Corporate Office:**  
**Administrative Building**  
**Gate 1, Paper Mill Compound**  
**Note Mudran Nagar, Mysuru - 570 003**  
**Telephone No. 0821 - 2401 111**

**e-mail: [scm.tender@bnpmindia.com](mailto:scm.tender@bnpmindia.com)**

**website: [www.bnpmindia.com](http://www.bnpmindia.com)**



## SECTION II - TERMS & CONDITIONS

1. Tenders are invited from eligible and qualified tenderers for supply of following goods:

S No.	Item Description	UOM	Quantity
1.	Clamping fingers for Rewinder unwinding chuck <ul style="list-style-type: none"><li>• MOC: EN08,</li><li>• DRG.NO: BNPM/FH/082/2019-20 (Refer Annexure-C)</li></ul>	Nos.	24

### 2. Quality parameters & delivery periods in scope of supply

- i. Successful bidder need to submit the Dimensional report of all items of Purchase order
- ii. Successful bidder need to supply 2 Nos of clamping finger for inspection at BNPM.
- iii. If the item is not made as per Purchase order specification, it is the Successful bidder's responsibility to repeat the same and to confirm Purchase order specification. This entire sample inspection process to be completed within 30 days from the receipt of purchase order.
- iv. BNPM will give the clearance of inspection by mail to the successful bidder within 4 days from the date of inspection call/ receipt of sample supplied at BNPM.
- v. After getting the inspection clearance from BNPM, the Successful bidder needs to supply all the materials within 30 days from the date of inspection clearance. On inspection of remaining material, if any deviation is found from the accepted sample, then new material need to supplied and then only rejected lot will be permitted to be taken out from BNPM.
- vi. Payment will be made only after supplying the complete Purchase order quantity and acceptance of the same.

### 3. Procedure for bid submission:

#### ONLINE:

- a) Interested bidders may obtain further information about this requirement from the above office selling the documents. They may also visit our website [www.tenderwizard.com/BNP](http://www.tenderwizard.com/BNP) mentioned above for further details.
- b) Aspiring Bidders/Contractors who have not registered in e-tendering should register through the website E - Tendering ([www.tenderwizard.com/BNP](http://www.tenderwizard.com/BNP)) for participating in the Online Tenders. The registration charges will be Rs. 500/- plus applicable taxes (per year) which needs to be paid through electronic mode only.
- c) For details, registration and e-payment, please visit e-tendering website [www.tenderwizard.com/BNP](http://www.tenderwizard.com/BNP) or contact KEONICS help desk @ 080-40482000.

## SECTION II - TERMS & CONDITIONS

- d) Class III Digital Signature Certificate (DSC) is mandatory to participate in e-Tenders. Participating bidders/Contractors have to make sure that they have the valid DSC. If not, they can procure from any of the firm as approved by CCA.
4. The tenderer shall satisfy BNPMIPL that they are competent and authorized to submit tender and/or to enter into a legally binding contract with the BNPMIPL. To this effect, any person giving a tender shall render documentary evidence that his signature on the tender submitted by him is legally binding upon himself, his firm or company as the case may be.
  5. BNPM reserves the right to cancel the tender at any stage without assigning the reasons thereof.
  6. Against receipt of the following notification through email from tender wizard, bidder must resubmit the bid even if the bidder have already submitted the bid through tender wizard.  
***Notification: If you have already submitted the tender, then ensure that you resubmit the tender. Else, your bid may be liable to be auto disqualified by the system. And service provider holds no responsibility for the same. In case, you are yet to submit the tender, then please ensure that you submit it before the tender closing time.***
  7. Submission / resubmission of the bid is the responsibility of the bidders only. Bidder should check and confirm at their end regarding the submission/ resubmission of their bid till the due date & time of bid submission. BNPM / Keonics/ Tender wizard will not be responsible for non-submission/ non resubmission of any bid.

\*\*\*\*\*

## **SECTION II – TERMS & CONDITIONS**

### **1. Documents to be submitted:**

- a) Signed copy of this document (All the pages).
- b) Filled price schedule as per Section III of this document.
- c) Technical details /datasheet for the enquired product (if applicable).
- d) Micro / Small Enterprise (MSE) (Certificate issued by only UDYAM certificate (If applicable).
- e) Manufacturing unit details (if any).

**2. Price:** Price should be inclusive of P&F, Freight, Transit Insurance and GST. Price shall remain fixed & no price variation shall be accepted till completion of contract.

**3. Terms of Payment:** 100% payment shall be made within 30 days after receipt and acceptance of complete supply at BNPM Plant, Mysuru, as per purchase order and on production of all required documents by the successful bidder. NEFT/RTGS details shall be furnished along with the Original Invoice.

### **4. Delivery Terms & Delivery Address:**

Delivery shall be made on F.O.R Basis, Bank Note Paper Mill India Pvt. Ltd., Mysore.

Engineering Stores, Bank Note Paper Mill India Pvt. Ltd., Note Mudran Nagar, Mysore - 570003. Stores contact details: 0821-2401476/486.

**5. Taxes:** All Taxes shall be as applicable in GST regime.

Payment of CGST, SGST, IGST & UTGST: The successful bidders are required to adhere the following procedure in order to honour the payment against CGST, SGST, IGST & UTGST in the invoice.

- i) An invoice issued by the vendor for goods or services or both as applicable should be in accordance with the provisions of Sec 31 of the CGST Act & should contain all the prescribed information's in accordance with Chapter VI of CGST rules 2017.
- ii) A debit note issued if any, by the vendor should be in accordance with the provisions of Sec 34 of the CGST Act.
- iii) The vendor should mandatorily upload the aforementioned documents in respective GSTR, details of outward supplies of goods or services as applicable within the prescribed time under GST Act.
- iv) The vendor should provide the relevant documents to confirm the tax charged on the invoice has been paid to the credit of government after adjusting the ITC if any.

Notwithstanding the above, the successful bidder should provide indemnification as follows:

In the event of non-compliances with respect to GST Act & Rules by the successful bidder, the purchaser is allowed to adjust the GST amount from retention amount (either in BG or in cash) held by the company. If no amount is available for recovery, the successful

## **SECTION II - TERMS & CONDITIONS**

bidder will refund the GST liability within 10 days from the date of GST reversal in GSTRN.

The above requirements are mandatory to claim any GST liability, failing which, the GST liability will not be paid /reimbursed/accepted.

### **A. The bidder should consider the following points while quoting GST Rate in their bids:**

1. In case of unregistered bidders, the rate and amount of GST shall be shown as "Nil".
2. In case of a compounding dealer, GST shall be quoted as "Nil" as compounded dealers cannot collect GST from the consumers. The price quoted therefore shall be construed as all inclusive.
3. In case of work contracts or pure labour contracts, the bidder shall quote single GST rate for the work.
4. In case of composite supplies, i.e., a supply consisting of one principal supply and other ancillary supplies, the supply will attract the GST Rate of the principal supply. For example, if Item A in the supply order is the major or principal supply and other items are ancillary supplies, the bidder shall quote the GST Rate applicable to the principal goods (i.e., Item A) being supplied.
5. In case of mixed supply, i.e., a combination of two or more individual goods made together for a single price (each of these items can be supplied separately and is not dependent on any other), the total supply will attract the GST rate of the item which has the highest rate of tax. For example, if Item A in the mixed supply attracts highest rate of tax, the bidder shall quote the GST rate applicable to item A for total mixed supply.
6. In case of supplies which are neither composite nor mixed supplies, the bidder shall quote the GST Rate applicable to each item of supply separately.
7. If there is any difference of opinion regarding classification in HSN code, the bidder should sought clarification/raise query within the given time from the date of tender and it would be clarified before submitting the bid. Once clarified then that will be final & binding and no deviation shall be granted.

### **B. Other instructions for the bidders to claim any GST liability, failing which, the GST liability will not be paid/reimbursed/accepted:**

1. Registered/compounding Contractor/ successful bidder should produce GST Invoice containing all the particulars stated in Rule 46 of the CGST Rules, 2017 in accordance with the provisions of Section 31 of the CGST ACT.
2. The successful bidder should mandatorily update the invoice details in GSTR-1, details of outward supplies of goods or services within the prescribed time under GST Act
3. The Payment shall be made net of TDS as per the provisions of CGST/SGST/IGST Act.
4. Wherever there is difference in the amount admitted, the successful bidder may be directed to issue a Credit Note (in case of reduction in the Invoice value)/Debit Note (in case of increase in the Invoice value), and payment shall be released only after the receipt of such Debit or Credit Note

## SECTION II - TERMS & CONDITIONS

5. The successful bidder should provide the relevant documents to confirm the tax charged on the invoice has been paid to the credit of Government after adjusting with ITC, if any.
6. The successful bidder should provide indemnification as follows: "In the event of non-compliances with respect to GST ACT and Rules by the successful bidder, the successful bidder should refund the GST liability within 10 days from the date of GST reversal in GSTRN failing which the purchaser shall recover the GST amount from the retention amount (whether in BG or in Cash) held by the company".

### **6. Warranty:**

The successful bidder warrants that the goods supplied under the contract is new, unused and incorporates all recent improvements in design and materials unless prescribed otherwise by BNPM in the contract. The successful bidder further warrants that the goods supplied under the contract shall have no defect arising from design, materials (except when the design adopted and / or the material used are as per BNPM's specifications) or workmanship or from any act or omission of the supplier, that may develop under normal use of the supplied goods under the conditions prevailing in India.

This warranty shall remain valid for twelve months after all the goods have been delivered to the final destination (i.e., BNPM Mysore) and accepted by BNPM in terms of the contract

In case of any claim arising out of this warranty, BNPM shall promptly notify the same in writing to the successful bidder, and the bidder has to repair/replace the same within 30 days of notification.

7. **Liquidated Damages (LD):** If the supplier fails to deliver any or all of the goods within the delivery period (as per PO), BNPM shall, without prejudice to other rights and remedies available to BNPM under the contract, deduct from the contract price, as liquidated damages, a sum equivalent to the 0.5% (Half) percent of the delivered price of the delayed goods for each week of delay or part thereof until actual delivery, subject to a maximum deduction of 10% of the delayed goods' contract price(s).
8. **Delay in successful bidder's performance:** Time for and the date specified in the contract or as extended for the delivery of the stores shall be deemed to be the essence of the contract and the successful bidder shall deliver the goods and perform the services under the contract within the time schedule specified by BNPM in the contract.  
  
Any delay attributable to the successful bidder in maintaining its contractual obligations towards delivery of goods and/or performance of services shall render the successful bidder liable to any or all the following sanctions besides any administrative action such as (a) Imposition of liquidity damages; (b) Termination of contract for default.
9. **Extension of Time:** If the contract is delayed in the progress of work by changes ordered in the work, or any clause which BNPM shall decide to justify the delay, then the time of completion shall be extended by a reasonable time.

## **SECTION II - TERMS & CONDITIONS**

If at any time during the currency of contract, the successful bidder encounters conditions hindering timely delivery of the goods and performance of services, the successful bidder shall promptly inform BNPM in writing about the same and its likely duration and make a request to BNPM for extension of the delivery schedule accordingly. On receiving the successful bidder's communication, BNPM shall examine the situation as soon as possible and, at its discretion, may agree to extend the delivery schedule, with or without liquidated damages for completion of successful bidder's contractual obligations by issuing an amendment to the contract.

**10. Rejection Replacement:** In case of supplies, materials not meeting BNPM specification will be rejected outright and the rejected material shall be taken back within 7 days at the cost and risk of the successful bidder and replacement should be made within 15 days from the date of intimation. No payment shall be made for rejected item. If the material is not taken back within the stipulate period, BNPM reserves the right to dispose-off the material at the risk and expense of the successful bidder.

**11. Risk Purchase Clause:** If the successful bidder fails to abide by the terms and conditions of the contract/agreement, or fails to supply the material as per the delivery schedule or any time repudiates the contract,

Procure the tendered item / render service from other agencies at the risk and cost of the successful bidder. The cost difference between the alternative arrangement and existing contract value wherein default has been made will be recovered from the successful bidder along with the other incidental charges.

In case of procurement through alternative sources, if procurement price is lower than the existing contract value wherein default has been made, in such case no benefit on this account will be passed on to the successful bidder.

**12. Termination for Convenience (Foreclosure) Clause:** BNPM reserves the right to terminate the contract, in whole or in part for its (BNPM's) convenience, by serving written notice on the successful bidder at any time during the currency of the contract. The notice shall specify that the termination is for the convenience of BNPM. The notice shall also indicate inter-alia, the extent to which the successful bidder's performance under the contract is terminated, and the date with effect from which such termination will become effective.

**13. Settlement of Disputes through Arbitration:** All disputes and differences of any kind whatsoever arising out of or in connection with the contract, whether during the progress of the work or after their completion except accepted matters shall be settled through arbitration process as per the Arbitration & Conciliation Act, 1996. The venue of arbitration shall be Mysore, Karnataka.

**14. Legal Jurisdiction:** The Courts of Mysore (Karnataka State) shall alone have jurisdiction to decide on any legal matter of dispute whatsoever arising out or in respect of the contract.



## **SECTION II - TERMS & CONDITIONS**

- 15. Force Majeure:** In the event of any unforeseen event directly interfering with the supply of stores arising during the currency of the contract, such as war, hostilities, acts of the public enemy, civil commotion, sabotage, fires, floods, explosions, epidemics, quarantine restrictions, strikes, lockouts, or acts of God, the Contractor shall, within a week from the commencement thereof, notify the same in writing to the Purchaser with reasonable evidence thereof. Unless otherwise directed by BNPM in writing, the successful bidder shall continue to perform its obligations under the contract as far as reasonably practical, and shall seek all reasonable alternative means for performance not prevented by the Force Majeure event. If the force majeure condition(s) mentioned above be in force for a period of 90 days or more at any time, either party shall have the option to terminate the contract on expiry of 90 days of commencement of such force majeure by giving 14 days' notice to the other party in writing. In case of such termination, no damages shall be claimed by either party against the other, save and except those which had occurred under any other clause of this contract prior to such termination.
- 16. Fore-Closure Clause:** If at any time during the continuation of this contract, the use of material ordered in this contract is completely banned or due to drastic change in Government policy its use as, raw material is discontinued or is declared hazardous to public health or cause rising to civil commotion, epidemics, wide-spread strikes and 21 days' notice of such eventualities is given by purchaser to the seller, the seller without any right to enforce the contract, will agree to the fore-close the performance of balance portion of this contract and in that event no claim for damages or loss will be lodged against the purchaser.
- 17. Rights of Rejection:** BNPMIPL reserves the right to reject any or all the applied bids without assigning any reason whatsoever. The enquiry can be rejected on national security grounds.
- 18. Note:**  
Catalogue/drawing of the quoted products have to be provided along with the bid
- 19. Evaluation Criteria:** Evaluation shall be done on the basis of **overall effective price** quoted by the bidder and the contract shall be awarded to the overall lowest (L1) bidder.
- 20. Tender Validity:** 90 (Ninety) days from the date of opening of the tender
- 21.** BNPM reserves the right to cancel the tender without providing any reason.
- 22. Price Discrepancy:**
- i. If, in the price structure quoted by a tenderer, there is discrepancy between the unit price and the total price (which is obtained by multiplying the unit price by the quantity), the unit price shall prevail and the total price corrected accordingly, unless BNPM feels that the tenderer has made a mistake in placing the decimal point in the unit price, in which case the total price as quoted shall prevail over the unit price and the unit price corrected accordingly.



## SECTION II - TERMS & CONDITIONS

- ii. If there is an error in a total price, which has been worked out through addition and/ or subtraction of subtotals, the subtotals shall prevail and the total corrected; and
- iii. If there is a discrepancy between the amount expressed in words and figures, the amount in words shall prevail.
- iv. If, as per the judgment of BNPM, there is any such arithmetical discrepancy in a tender, the same will be suitably conveyed to the tenderer by registered/speed post. If the tenderer does not agree to the observation of BNPM, the tender is liable to be ignored.
- v. If there is any tie between the quoted L1 rates of the bidders then preference will be provided to the company which was constituted earlier.
- vi. Note: In techno commercial bid, Bidders have to mandatorily submit Company's registration / Certificate of incorporation/Partnership Deed/Any other registration certificate as applicable substantiating documentary evidence pertaining to date of constitution of the company.

## SECTION III - PRICE SCHEDULE

**Tender No.: BNPM/OTE/359/2024-25 dated: 06.11.2024**

Sch. No	Material Description	UOM	Qty.	Offered Make (If applicable)	Unit Price (INR)	P&F, Insurance & Freight Charges (INR)	GST@ Amount (INR)	Unit price including P&F, Insurance, Freight & GST (INR)	Total price inclusive of P&F, Insurance, Freight & GST (F.O.R, BNPM, Mysuru) (INR)	Input GST Credit (INR) {GST amount * Total quantity}	Effective price inclusive of P&F, Insurance, Freight (F.O.R, BNPM, Mysuru) (INR)
A	B	C	D		E	F	G	H=E+F+G	I=H*D	J=G*D	K=I-J
1.	Clamping fingers for Rewinder unwinding chuck <ul style="list-style-type: none"> <li>MOC: EN08,</li> <li>DRG.NO: BNPM/FH/082/2019-20</li> </ul>	Nos.	24								
	.Total effective price (net of input tax credit) for Supply of Clamping Fingers with freight, P&F, Transit Insurance and any other charges (F.O.R – BNPM, Mysore site) (in Figures) (INR)										
	Total effective price (net of input tax credit) for Supply of Clamping Fingers with freight, P&F, Transit Insurance and any other charges (F.O.R – BNPM, Mysore site) (in words) (INR)										
	Grand Total price for Supply of Clamping Finger inclusive of P&F, Insurance, Freight & GST (in Figures) (INR)										

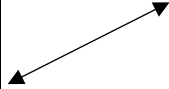

## SECTION III – PRICE SCHEDULE

	Grand Total price for Supply of Clamping Finger inclusive of P&F, Insurance, Freight & GST (in words) (INR)	
--	---	---

**Note:**

1. Evaluation Criteria: Price Evaluation shall be carried out on the basis of **overall effective price (i.e., without GST)** quoted by the bidder and contract shall be awarded to overall lowest (L1) bidder
2. This is a single stage, single envelope tender. Techno-commercial and Price Bid will be opened together.
3. Bid is to be submitted online only

## SECTION IV – DECLARATION

We hereby confirm that

1. We accept all the terms & conditions mentioned in the enquiry.
2. Price quoted is inclusive of P&F, Insurance, Freight and GST on F.O.R Basis, BNPM Plant, Mysore.
3. HSN Code: Item .....
4. GST registration status: Unregistered / compounding / registered.
5. Delivery period: As per tender terms
6. Warranty Period: ..... Months (Time Period is to be specified in case warranty period is less than 12 months / NA to mentioned in the in-case warranty is not applicable)
7. Bid validity: 90 days from date of closing of tender including extensions/ corrigendum's (if any). Bid Security declaration has been submitted as per format.

**8. Bank Details (Enclosed - Cancelled Cheque/ Bank Mandate):**

Bank Acc. No. ....;

Bank Acc Name: .....

Branch name: .....; Branch Code: .....

IFSC: .....

9. MSME / NSIC status: UDYAM:..... (If yes, then supporting document shall be submitted along with the offer to avail the benefits under the Procurement Policy for MSEs, Order 2012 along with its amendments.)

(Please fill above: MSI – For Micro Enterprises; SSI – For Small Enterprises; MED.SI – For Medium Enterprises; NSIC – For National Small Industries Corporation regd. firm)

10. Technical Data sheet/ Product Catalogue (Submitted/ Not submitted).

Signature of bidder: .....

Name of the Firm: .....

Seal of the firm: .....

GST No.: .....

**Contact Details: -**

Contact Person: .....

Contact Number: .....

E-mail Id: .....



**SECTION IV - DECLARATION**

**ANNEXURE -A**

**E-Tender No: BNPM/OTE/359/2024-25 dated: 06.11.2024**

**(To be submitted on Company letterhead)**

**DECLARATION**

I have read the clause regarding restrictions on procurement from a bidder of a country which shares a land border with India. I hereby certify that, M/s ..... is not from such a country or, if from such a country, has been registered with the Competent Authority. I hereby certify that M/s ..... fulfills all requirements in this regard and is eligible to be considered.” (Where applicable, evidence of valid registration by the Competent Authority shall be attached.)

I, the undersigned, declare that the item ..... originate in ..... (Name of the country).

Signature \_\_\_\_\_

Name-----

Designation-----

Date-----

Stamp of the Organization-----



## SECTION IV - DECLARATION

### ANNEXURE-B

**E-Tender No.: BNPM/OTE/359/2024-25 dated: 06.11.2024**

**(To be submitted on Company letterhead)**

### BID SECURITY DECLARATION

We, the undersigned, declare that we will automatically be suspended from being eligible for bidding in any tender with Bank Paper Mill India Private Limited, Mysore for the period of 12 months, if we are withdrawing our Bid during the period of bid validity (or) fail / refuse to furnish the performance security / execute the contract, if awarded.

Signature \_\_\_\_\_

Name-----

Designation-----

Date-----

Stamp of the Organization-----

ANNEXURE-C

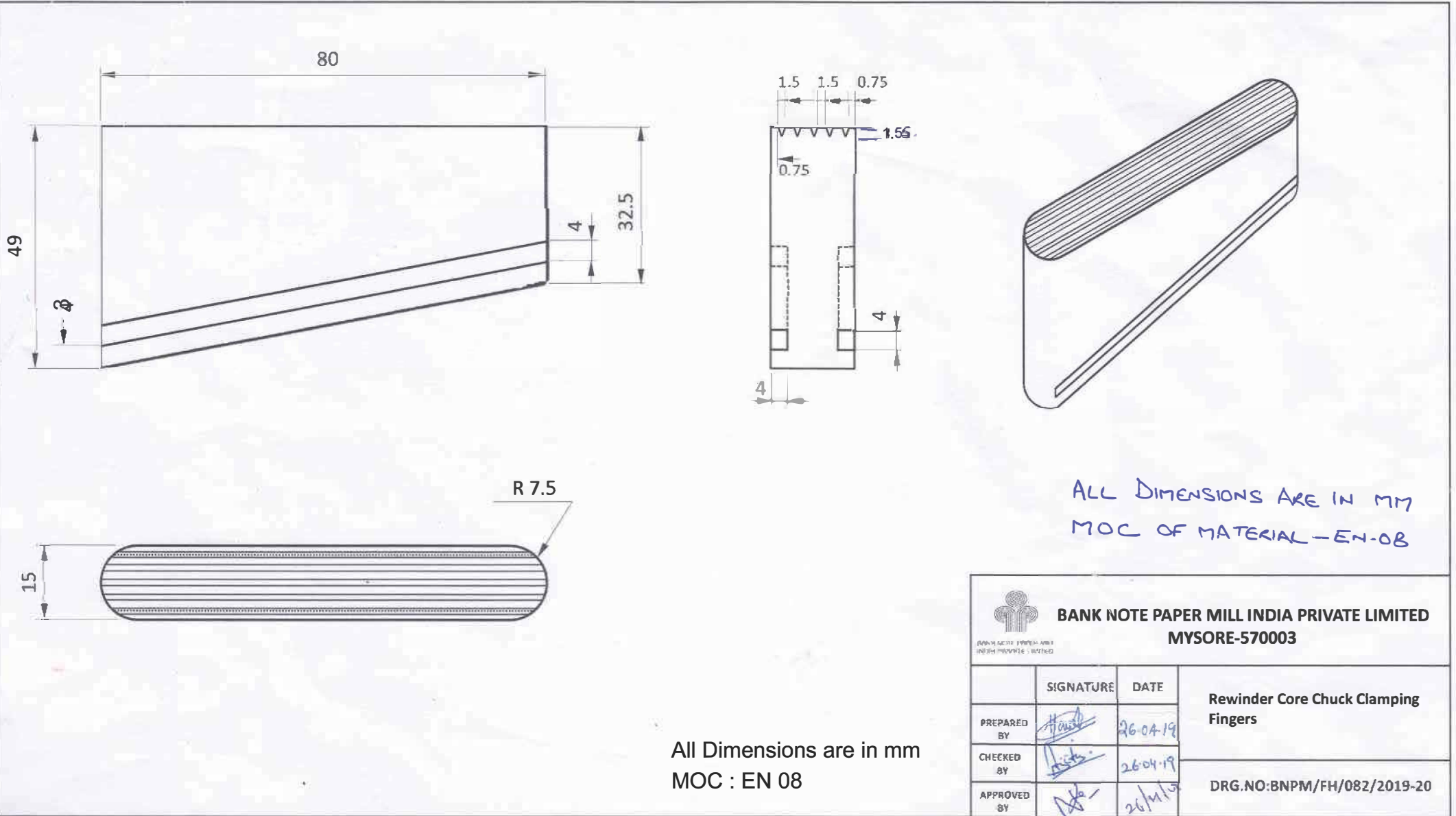

All Dimensions are in mm  
MOC : EN 08